

- PRE-FORMED CORNER PROFILES · XPS + CEMENTITIOUS
- § 01 PRODUCT OVERVIEW

ANGLE BOARD.

- PRE-FORMED 90°
 - WATERPROOF
 - FACTORY V-SCORED
- FOR WET-AREA CORNERS

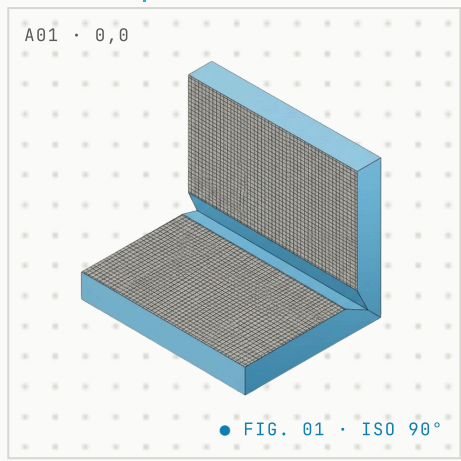

§ 01 · DESCRIPTION

INSUTILE® Angle Board is a pre-formed 90° corner profile made from the same XPS + cementitious construction as our Build Board — factory V-scored and folded to a permanent right angle. It replaces mitred-on-site backer board joints at internal corners in wet areas.

No cold joints, no alignment error, no waterproofing failure at the crease. Drop in, tape the wings to the wall, and proceed straight to waterproofing and tile — with identical thermal, compressive, and water-resistance properties to the flat boards it connects.

§ 02 · KEY FEATURES

<ul style="list-style-type: none"> • 01 <p>Pre-Formed 90° Corner</p>	<ul style="list-style-type: none"> • 02 <p>Eliminates Mitred Joints</p>	<ul style="list-style-type: none"> • 03 <p>Continuous Waterproof Skin</p>	<ul style="list-style-type: none"> • 04 <p>Factory V-Scored XPS</p>	<ul style="list-style-type: none"> • 05 <p>High Mechanical Strength</p>
<ul style="list-style-type: none"> • 06 <p>Excellent Tile Adhesion</p>	<ul style="list-style-type: none"> • 07 <p>Thermal Insulation</p>	<ul style="list-style-type: none"> • 08 <p>Mould & Mildew Resistant</p>	<ul style="list-style-type: none"> • 09 <p>Fast Wet-Area Install</p>	<ul style="list-style-type: none"> • 10 <p>Bonds With Any Backer</p>

§ 03 · APPLICATIONS

- Shower & Wet-Room Corners
- Bathtub Surround Internal Angles
- Steam-Room Walls
- Wet-Area Wall-to-Floor Junctions
- Kitchen Splashback Corners
- Spa & Pool Surround Corners
- Tiled Bench & Seat Corners
- Renovation Retrofit
- Commercial & Residential Wet Areas



- § 04 · DIMENSIONS MATRIX

Available sizes.

Four standard sizes, all 20 mm thick. Each panel folds to a permanent 90° — dimensions describe one wing (width × length). Custom sizes available on request.

THICKNESS (MM)	WIDTH (MM)	LENGTH (MM)
20	150	150
20	200	200
20	300	300
20	400	200

- § 05 · TECHNICAL SPECIFICATIONS

INSUTILE® reserves the right to modify specifications at any time without prior notice.

PROPERTY	VALUE	STANDARD / NOTE
FOLDING ANGLE	90°	Custom on request
OPTIONAL FIXING	Pre-applied double-sided tape	Factory option
CORE MATERIAL	Extruded polystyrene (XPS)	Closed-cell, high-density
SURFACE FINISH	Cementitious, fibreglass mesh	Both faces
WATER ABSORPTION	≤ 0.1 %	EN 12087
CAPILLARY WATER UPTAKE	0 (none)	EN 1604
WATER PERMEABILITY	0 (impermeable)	EN 1604
COMPRESSIVE STRENGTH	≥ 300 kPa	EN 826
THERMAL CONDUCTIVITY	$\lambda \leq 0.036$ W/mK	EN 1604
REACTION TO FIRE	Class E	EN 13501-1

- NOTE · 01 / MADE TO ORDER

Specifications are configured per project. Dimensions, thickness, density and edge treatment can be adjusted to suit site conditions and application. Contact our technical team for project-specific specification, tolerances and lead times.

MANUFACTURED BY

INSUTILE®

DOC · AB-DS-001 / REV 04 · 2026
© INSUTILE® · ALL RIGHTS RESERVED

